

# Story

## Story TP

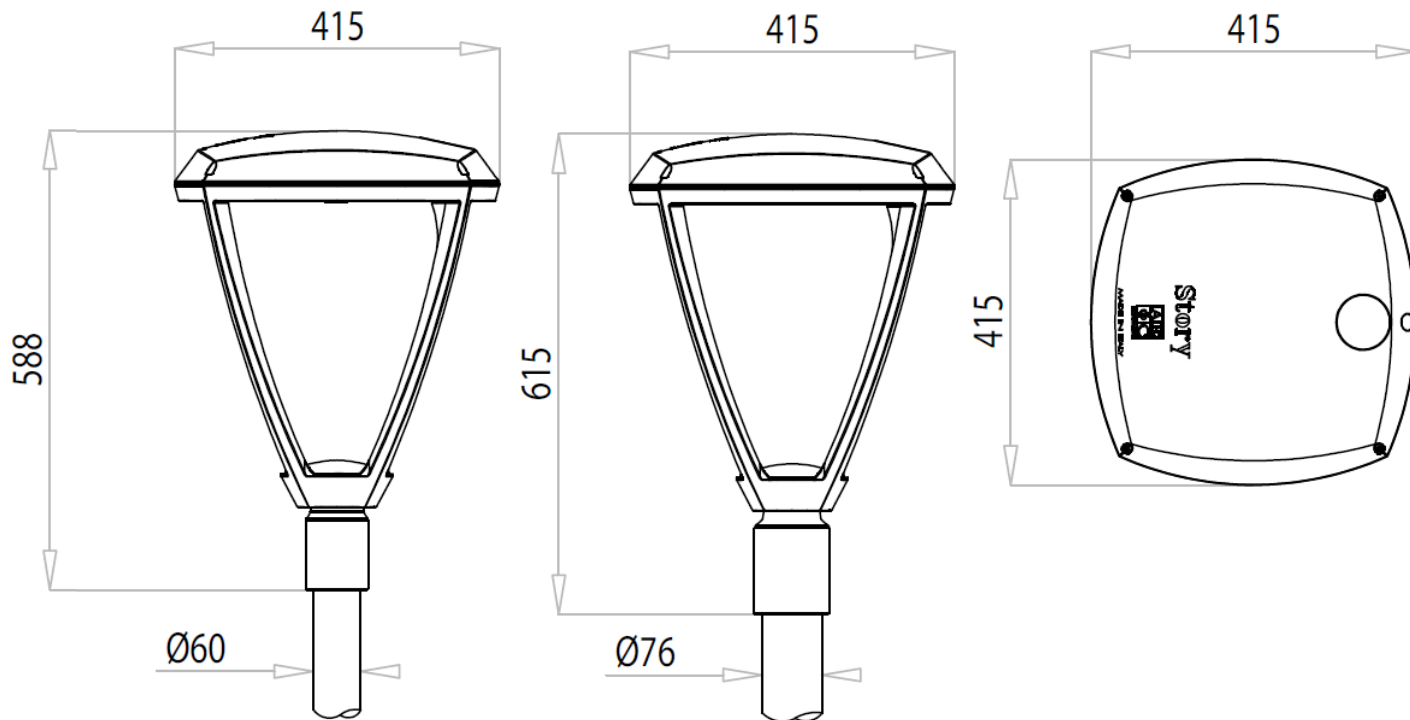

## Story S

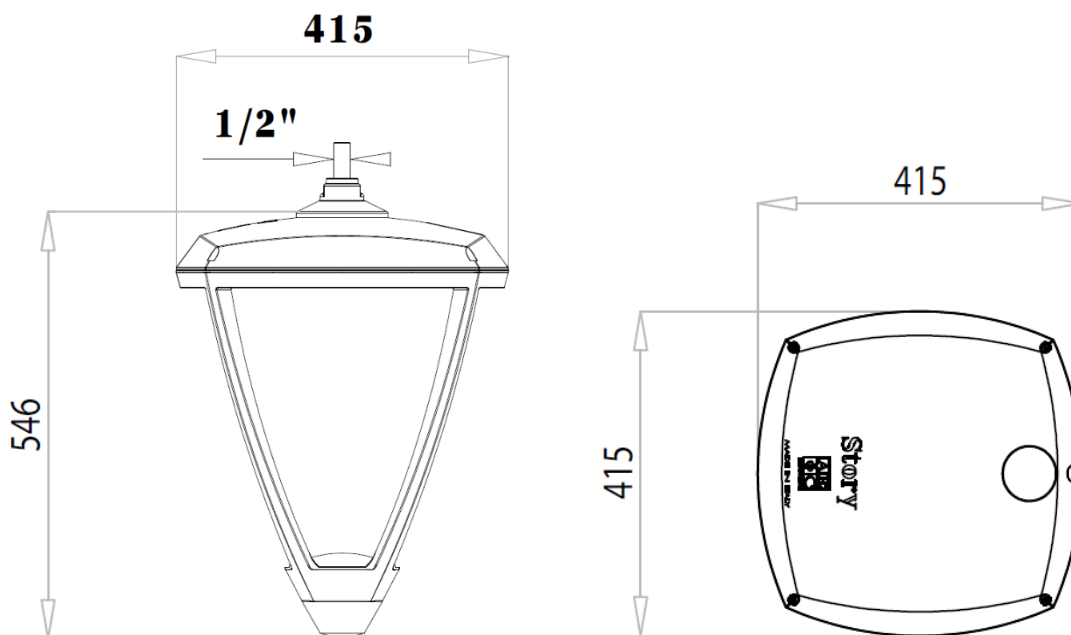

## Story TP Story S

SUPERFICIE LATERALE	SIDE AERA	WINDANGRIFFSFLÄCHE (SEITE)	0.07 m <sup>2</sup>	0.07 m <sup>2</sup>
SUPERFICIE LATERALE (con schermo)	SIDE AERA (with plastic screen)	WINDANGRIFFSFLÄCHE (SEITE)	0.15 m <sup>2</sup>	0.15 m <sup>2</sup>
SUPERFICIE DI BASE	BASE AREA	WINTANGRIFFSFLÄCHE (OBEN)	0.15 m <sup>2</sup>	0.15 m <sup>2</sup>
PESO (Max)	WEIGHT (Max)	GEWICHT (Max)	10.0 kg	10.0 kg
COEFFICIENTE DI FORMA	FORM FACTOR	FORM FACTOR	1.2	
MAX ALTEZZA DI INSTALLAZIONE	MAX HEIGHT OF INSTALLATION	MONTAGEHÖHE (Max)	15 m	
TA USO	TA USE	TA ANWENDUNGSBEREICH	50°C Outdoor	
IEC/EN 62471				
EXEMPT GROUP				
IEC/TR 62778 - RG1-RG2 (C-Max):				
0.40m ÷ 4.60m*				
IEC/TR 62778 - RG1-RG2 (C-90):				
0.6m ÷ 2m*				

\* In funzione della potenza e dal tipo di apparecchio  
\* According to the wattage and the type of the luminaire  
\* In Abhängigkeit zur Systemleistung und Variante

# Story

## 1 Story TP

N° 2 grani N°2 grub screws N° 2 Schrauben
M8

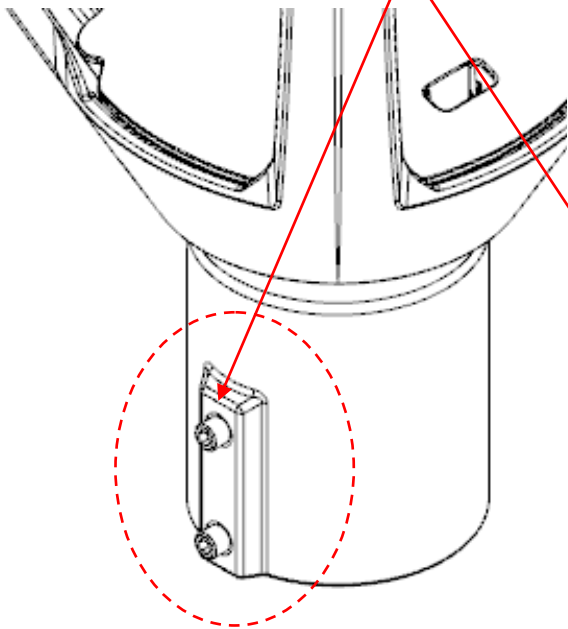
4mm
8Nm

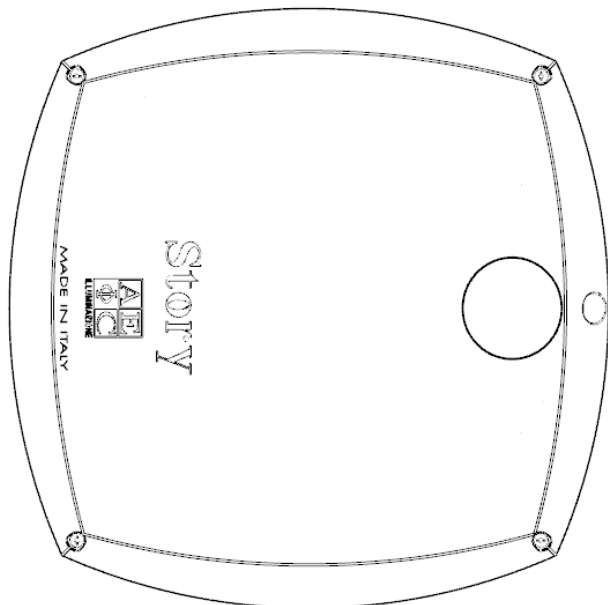
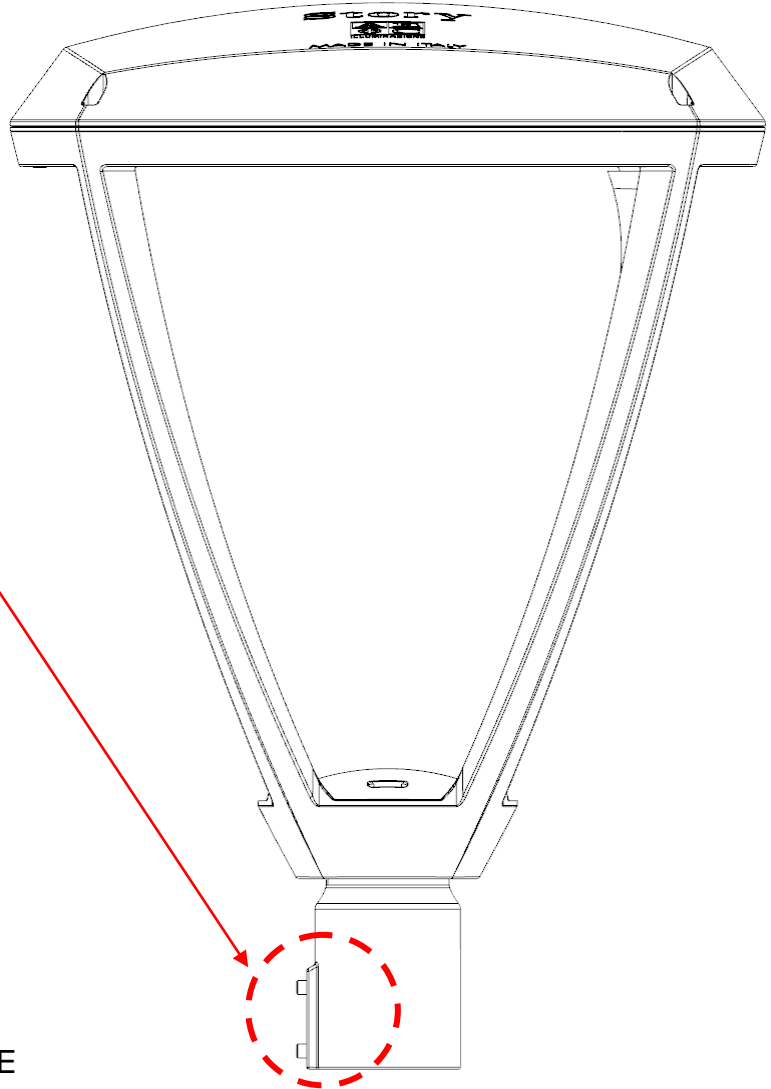

STRADA - STREET - STRAÙE



MARCIAPIEDE - SIDEWALK - STRAÙENSEITE

# Story

## 2 Story S

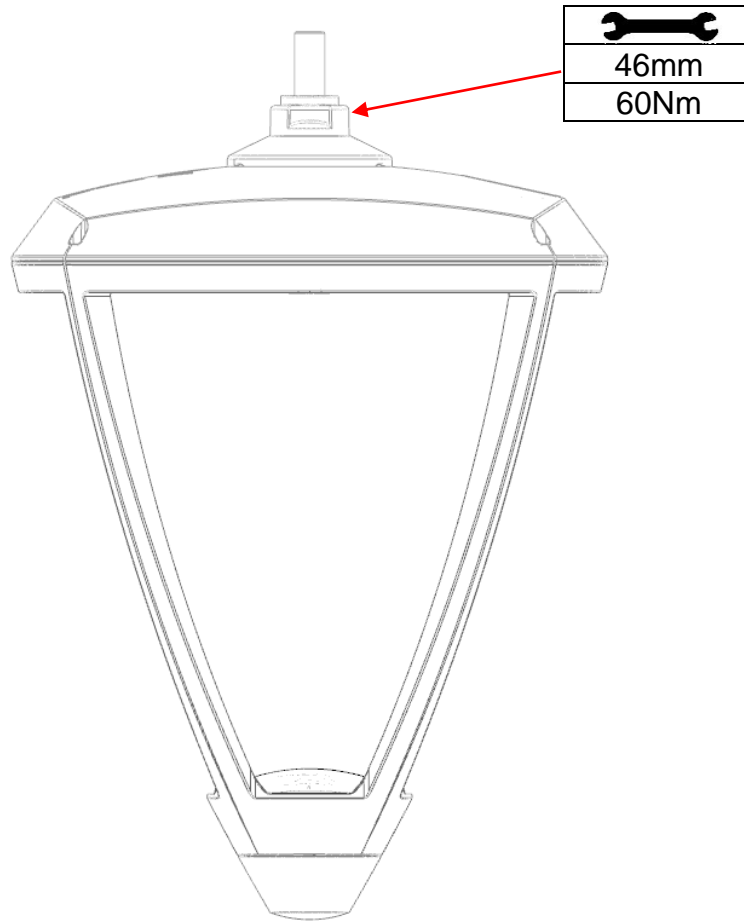

STRADA - STREET - STRAÙE

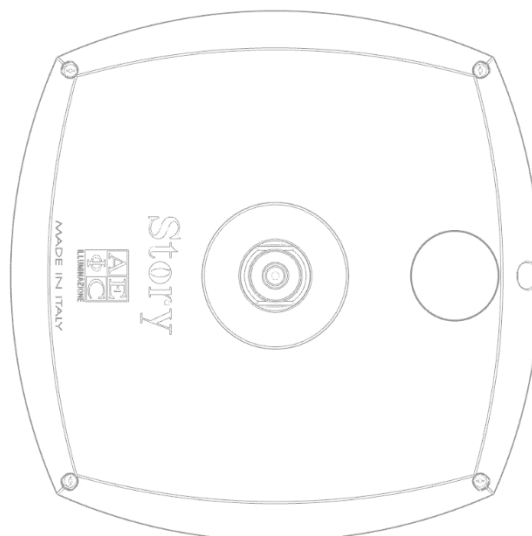

MARCIAPIEDE - SIDEWALK - STRAÙENSEITE

**3** Connessione elettrica cl.1 e cl.2 - Apparecchio con cavo uscente  
 Electrical line connection cl.1 and cl.2 - Luminaire with outgoing cable  
 Elektrischer Anschluss ks.1 und ks.2 - Gerät mit Ausgehenden Kabel

STORY è un apparecchio dove non è inclusa la morsettiera, quindi l'installazione può richiedere l'intervento di personale qualificato.

STORY is a luminaire without terminal block, so the installation may require advice from a qualified person.

Der Anschluss der Leuchte am Stromnetz bedarf den Einsatz von Fachpersonal!

### Caratteristiche del connettore o della scatola di derivazione

#### Connector or junction box characteristics

#### Eigenschaften des Steckverbinders oder der Anschlussdose

Il collegamento elettrico dentro la scatola di derivazione deve mantenere lo stesso grado di protezione alla scossa elettrica dell'apparecchio.

The electrical connections internal to the junction box have to maintain the same insulation class of the luminaire.

Die elektrische Verbindung innerhalb der Anschlussdose muss den gleichen Schutzgrad gegen den elektrischen Schlag des Geräts gewährleisten

<b>Grado di protezione</b> <b>Protection degree</b> <b>Schutzgrad</b>	≥ IP66			
<b>Morsettiera di alimentazione</b> <b>Mains terminal</b> <b>Stromanschlussleiste</b>	Conforme alla IEC/EN 60998-2-1 o IEC/EN 60998-2-2 Complies to IEC/EN 60998-2-1 o IEC/EN 60998-2-2 Entspricht dem IEC/EN 60998-2-1 o IEC/EN 60998-2-2			
<b>N° di poli</b> <b>N° of poles</b> <b>Anzahl der Pole</b>	2 (cl.2)	3 (cl.1) (cl.2 - DB)	4 (cl.1 - DB) (cl.2 - DALI)	5 (cl.1 - DALI)
<b>Tensione e corrente nominale</b> <b>Nominal voltage and current</b> <b>Spannung und Nennstrom</b>	400/450 Vac _ 6A			
<b>Sezione morsetti</b> <b>Terminals section</b> <b>Terminalabschnitt</b>	0.75 ÷ 2.5 mm <sup>2</sup>			

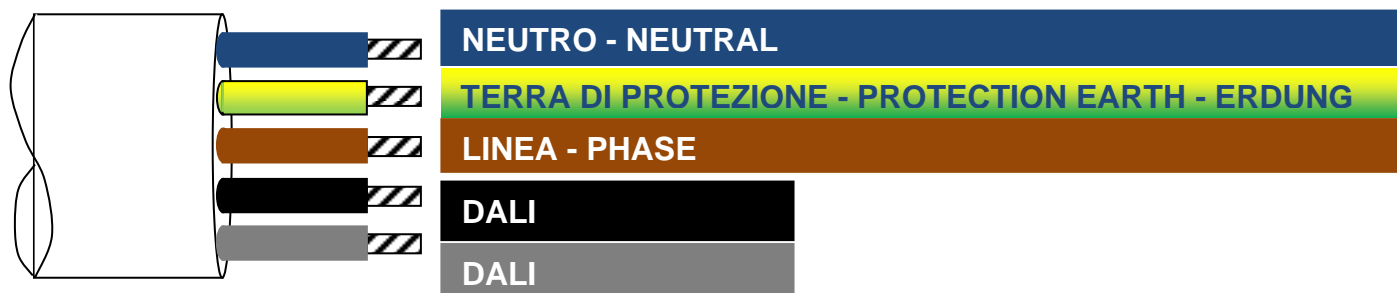

# Story

## Connessione elettrica cl.1 e cl.2 - Apparecchio con connettore

### 4 Electrical line connection cl.1 and cl.2 - Luminaire with external connector Elektrischer Anschluss ks.1 und ks.2 - Gerät mit Stecker



Connettore da collegare all'apparecchio.  
Connect this connector to the luminaire.  
Anschluss, der mit dem Gerät verbunden werden soll.

Connettore da collegare al cavo di alimentazione.  
Connect this connector to the mains cable.  
Anschluss zum Anschließen an das Netzkabel

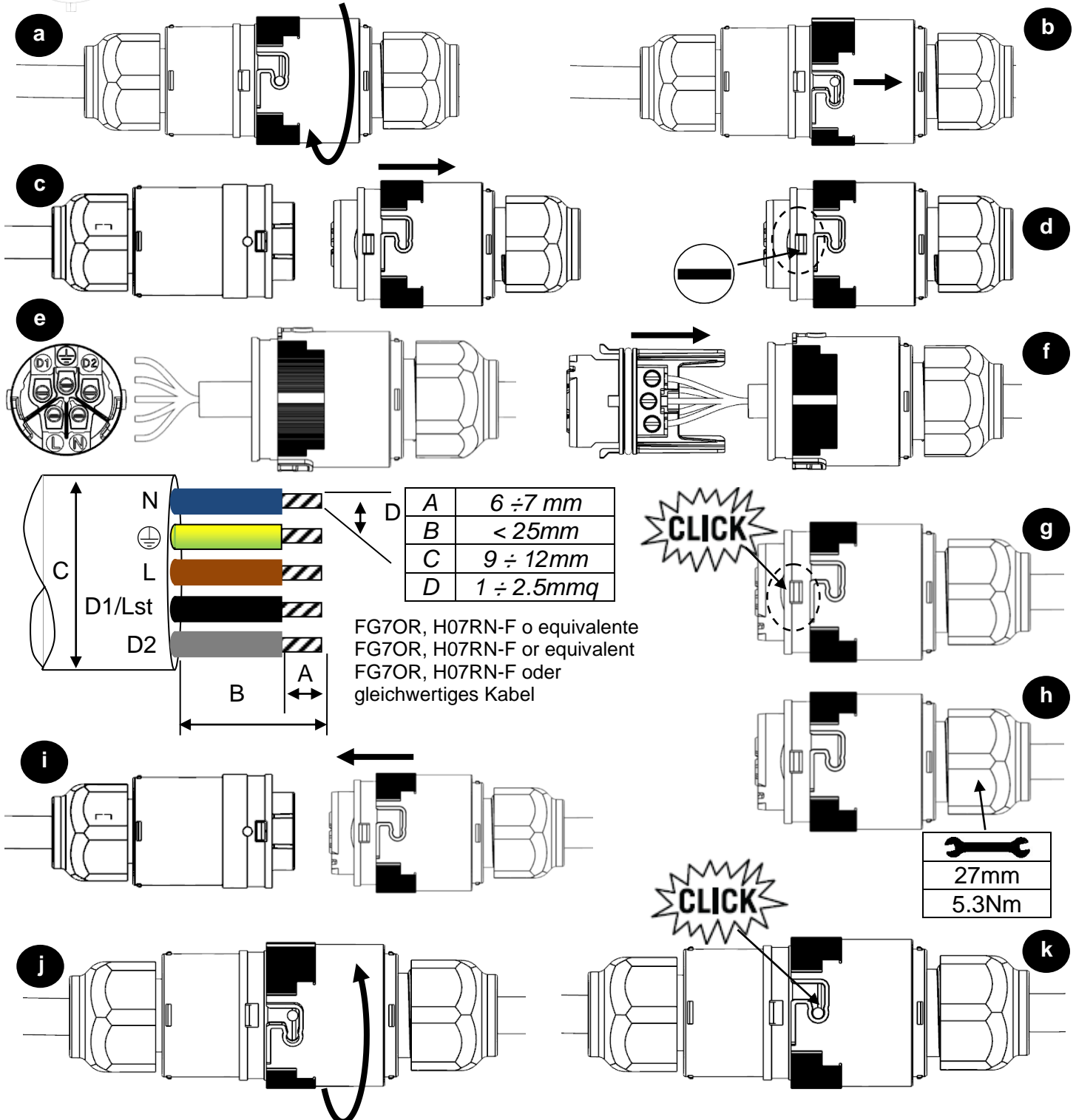
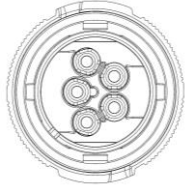

# Story

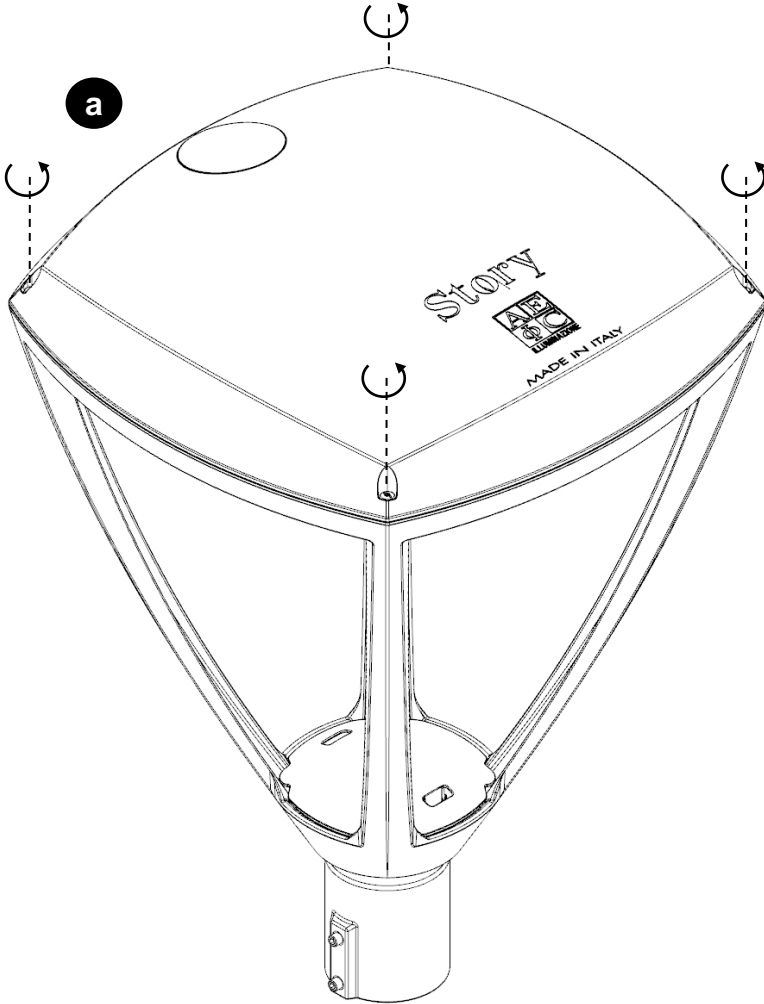

## 5 Apertura apparecchio – Luminaire opening - Gerät öffnung

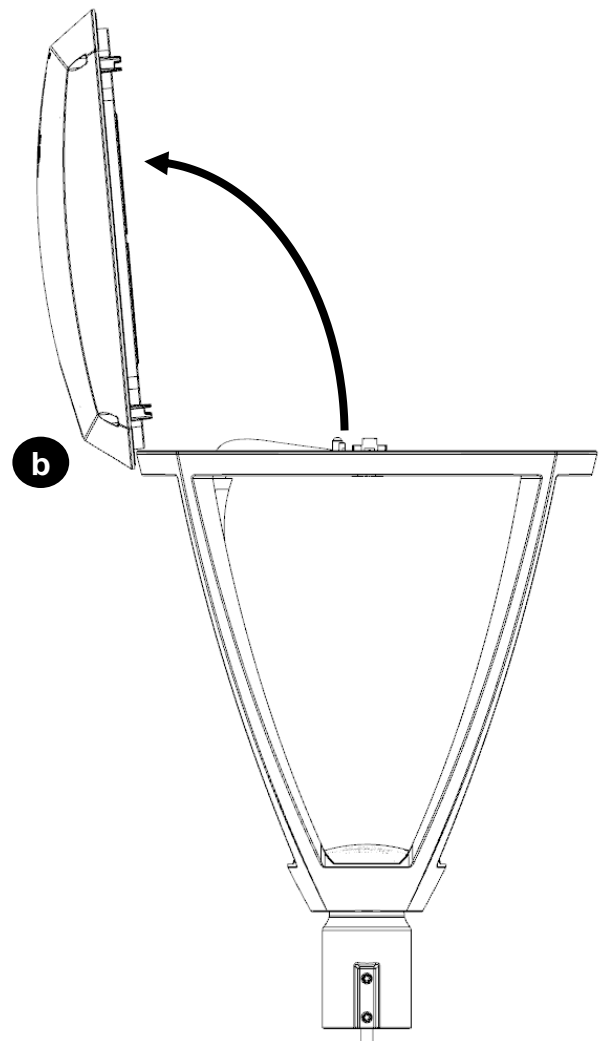

N°4 viti N°4 screws N°4 Schrauben
M5

TX25

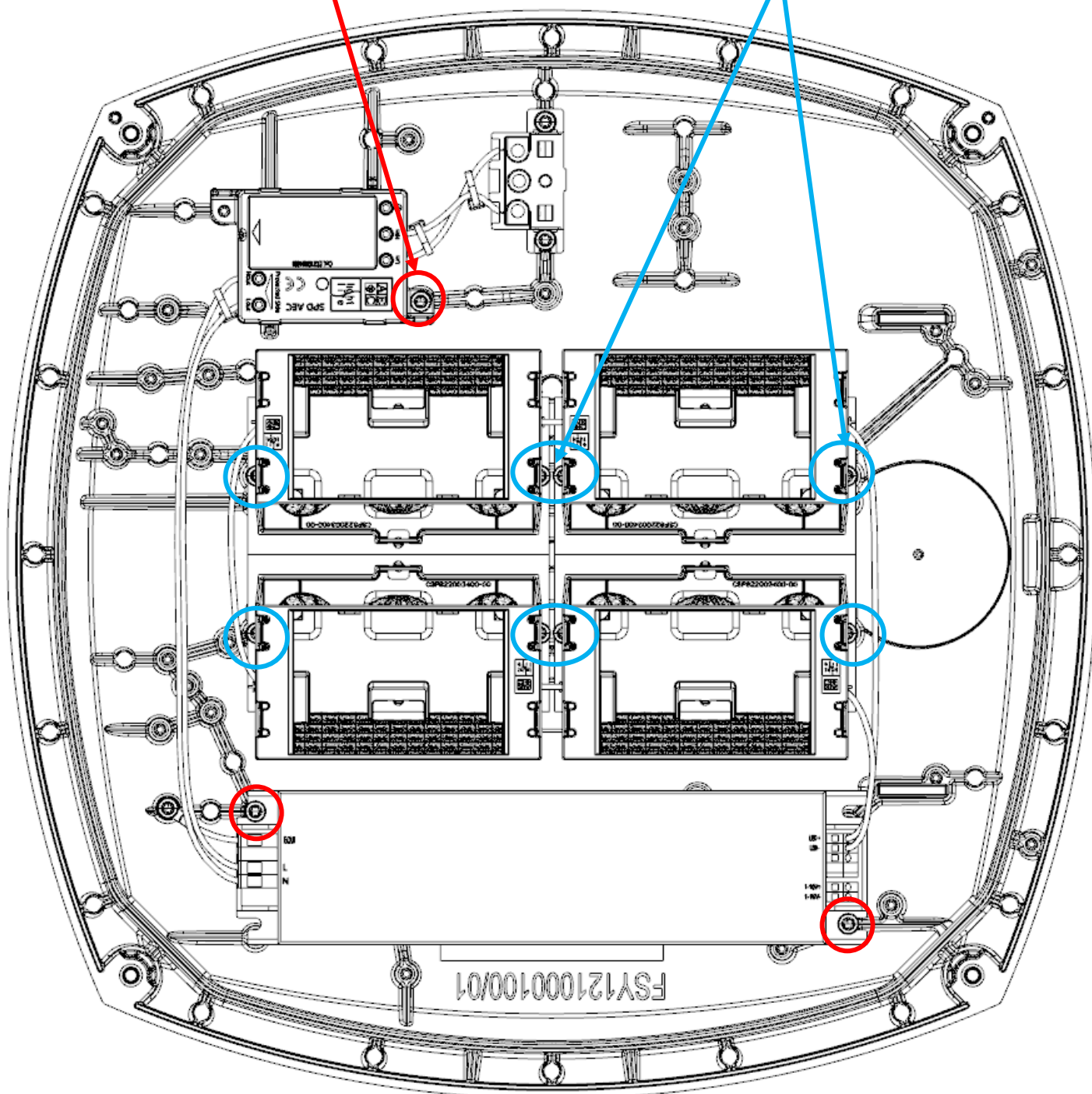

## 6 Manutenzione interna - Internal maintenance - Interne Wartung

<b>a</b>	 TX20 1Nm	Viti che fissano i componenti elettronici Screws that fix the electronic component Schrauben, die die elektronischen Komponenten befestigen	n°2 viti che fissano ogni PCB n°2 screws that fix the PCB 2 Schrauben, die jede Leiterplatte befestigen	<b>b</b>	 TX20 1Nm
----------	--	---	---	----------	--





## 7 Chiusura apparecchio – Luminaire closure - Leuchte schließen

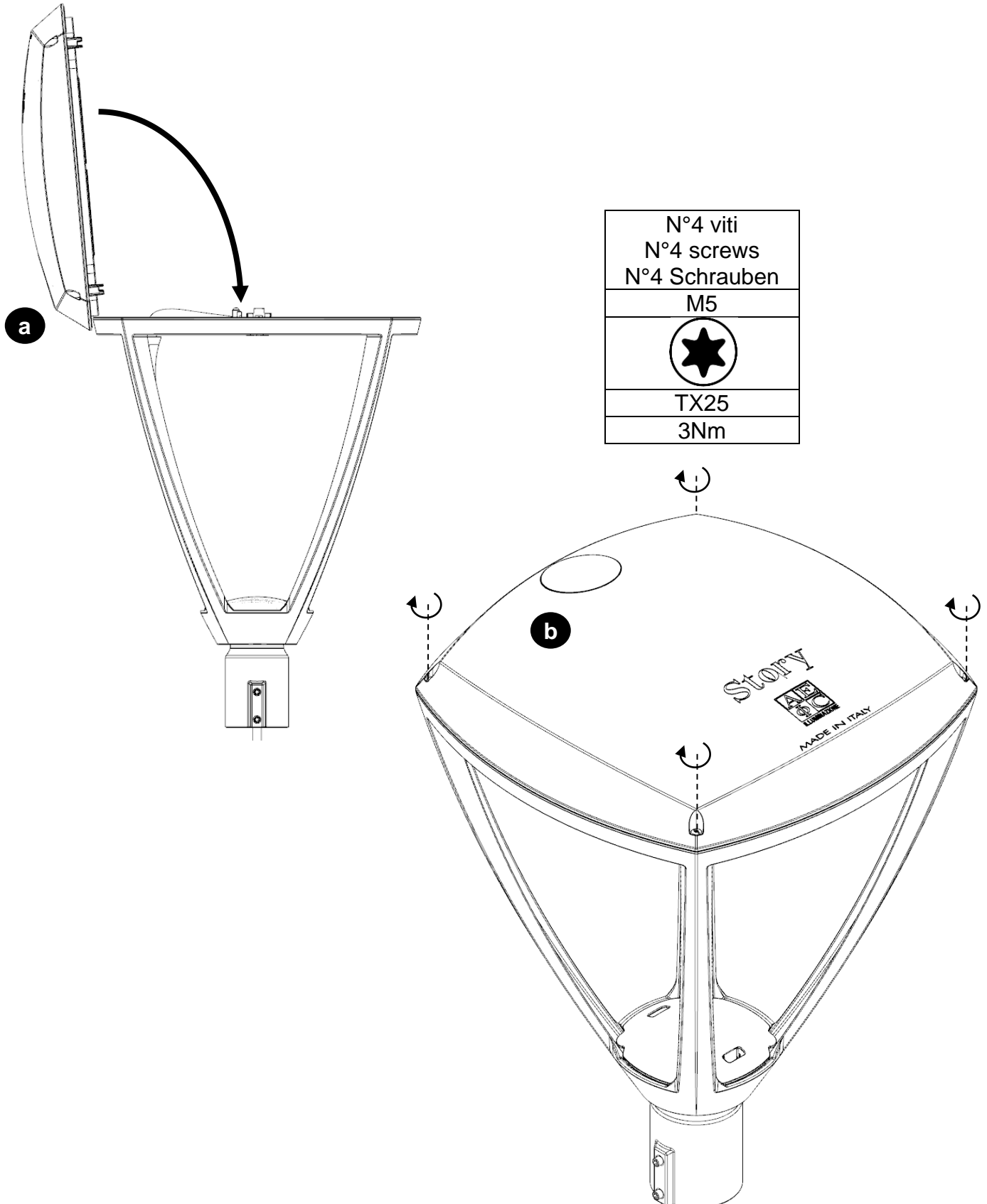

## 8 Schema elettrico - Electrical scheme - Schaltplan

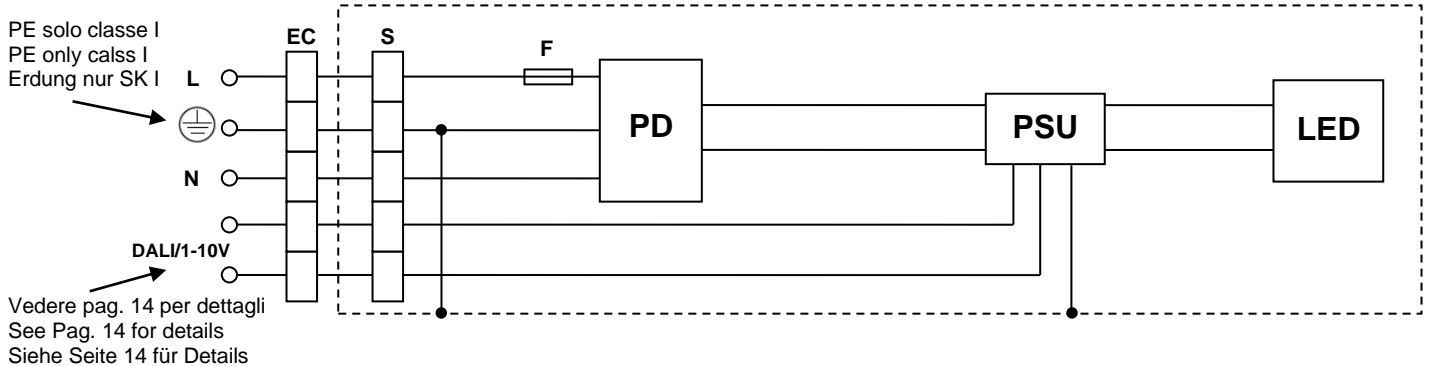

## Schema elettrico WL - WL electrical scheme - WL Schaltplan

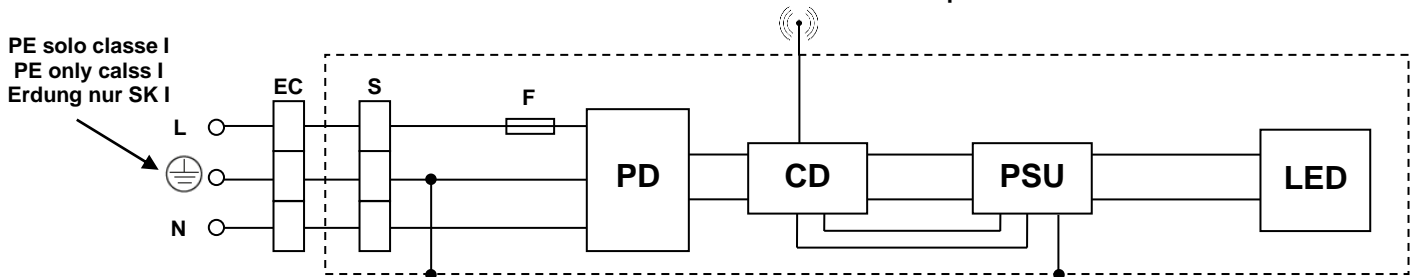

## Schema elettrico nema socket (versione CP) - Nema socket electrical scheme (CP version) - Schaltplan mit Nema Socket (CP version)

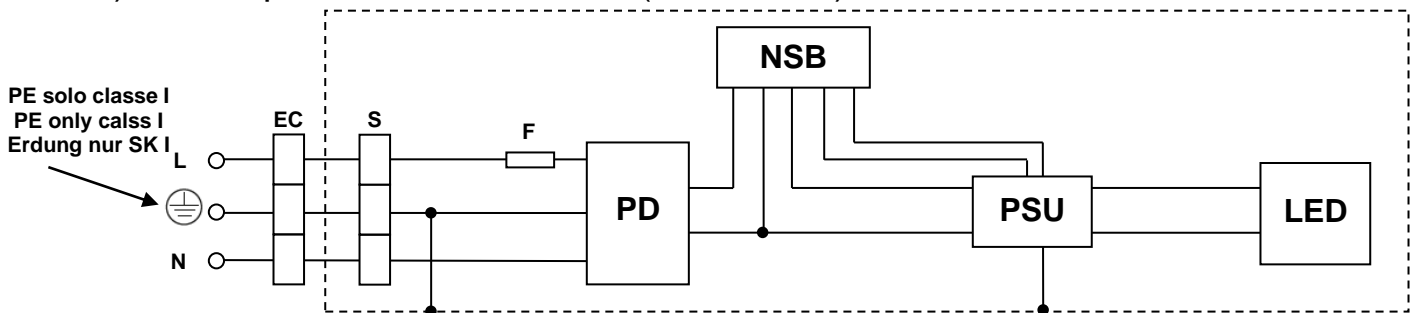

## Schema elettrico con Zhaga - Zhaga electrical scheme - Schaltplan mit Zhaga

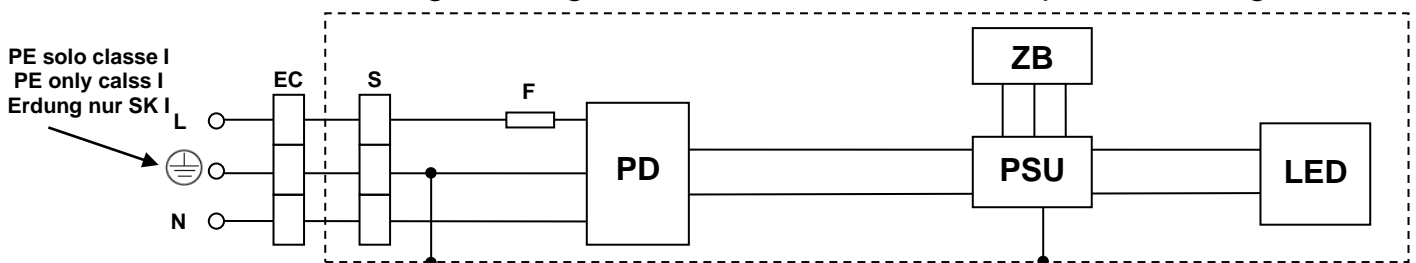

EC	Connettore esterno	External connector	Stecker
S	Sezionatore	Safety interlock	Trennschalter
F	Fusibile 250Vac 10A (taglia consigliata)	Fuse 250Vac 10A(suggested size)	Sicherung 250Vac 10A (optional)
CD	Dispositivo di telecontrollo	Control device	Steuermodul
PD	Circuito di protezione	Protection device	Überspannungsschutz
NSB	Base Nema socket	Nema socket base	Nema Steckdose
ZB	Base Zhaga	Zhaga base	Zhaga Steckdose
PSU	Alimentatore LED	LED power supply	Led-Treiber

9

## MANUTENZIONE SPD (optional)

Il dispositivo di protezione installato nell'apparecchio è dotato di un sistema di interruzione del circuito a fine vita che esclude l'alimentazione dell'apparecchio.

In caso di spegnimento dell'apparecchio ad impianto alimentato, controllare l'attività del dispositivo tramite il LED di segnalazione.

## SPD MAINTENANCE (optional)

The protection device is equipped with system that excludes power supply at the end of life of the luminaire. If the luminaire switches-off when the system is still fed, the activity of the protection device should be checked looking at signaling LED.

## SPD ÜBERSPANNUNGSSCHUTZMODUL (optional)

Der Überspannungsschutz hat ein System das die Stromversorgung am Ende der Lebensdauer der Leuchte abschaltet.

Wenn die Leuchte bei anliegender Netzspannung abschaltet, sollte der Überspannungsschutz überprüft werden (Signal-LED).

**LED ACCESO: Scaricatore funzionante**  
**LED ON: Right functioning of SPD**  
**LED leuchtet: SPD-Modul funktioniert**

**LED SPENTO: Scaricatore a fine vita da sostituire**  
**LED OFF: Replace the SPD**  
**LED aus: SPD-Modul muss ausgetauscht werden**

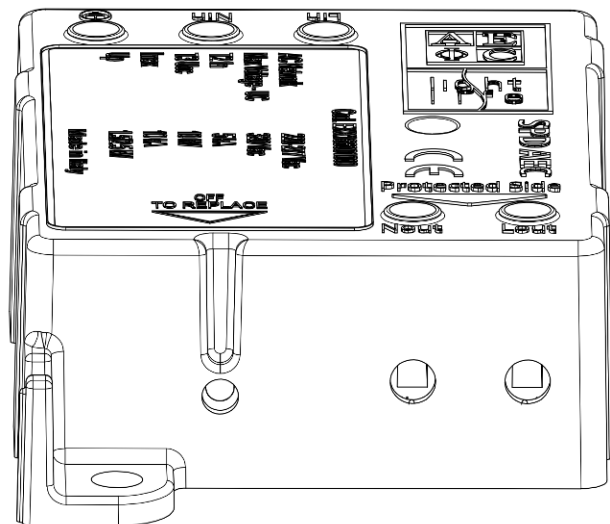
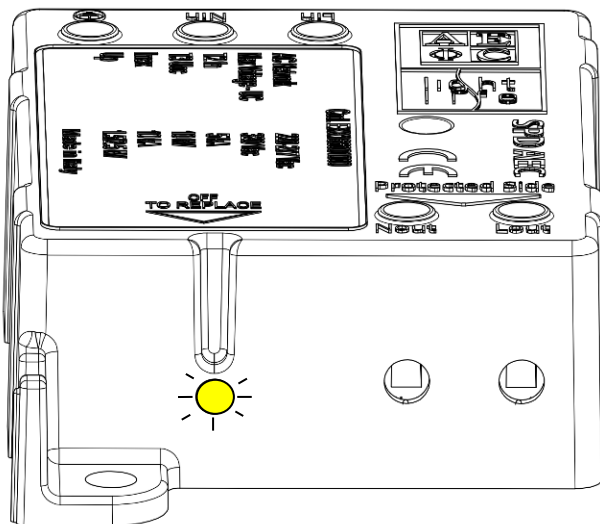



## INFORMAZIONI AGLI UTENTI

**Smaltimento di vecchie apparecchiature elettriche ed elettroniche (Applicabile nell'Unione Europea e negli altri paesi europei con sistema di raccolta differenziata).**

L'applicazione di questo simbolo sui prodotti o sui loro imballaggi indica che questo prodotto non deve essere trattato come un rifiuto domestico. Per ridurre l'impatto ambientale delle apparecchiature elettriche ed elettroniche di rifiuto (WEEE (Waste Electrical and Electronic Equipment)) e per minimizzare il volume dei WEEE che entra nelle discariche, si prega di procedere al riutilizzo e al riciclaggio. Per ulteriori informazioni, mettersi in contatto con il proprio rivenditore locale o con i distributori.

## ATTENZIONE

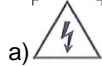

a)



b)



c)

- La sorgente luminosa contenuta in questo apparecchio deve essere sostituita solo dal costruttore o dal suo servizio di assistenza o da personale altrettanto qualificato.
- Sostituire gli schermi di protezione danneggiati.
- Non fissare la sorgente luminosa durante la manutenzione.
- Il cavo di alimentazione dell'apparecchio deve essere sostituito solo dal costruttore o dal suo servizio di assistenza o da personale qualificato.
- L'apparecchio in classe II deve essere installato in modo che le parti metalliche esposte non siano in contatto elettrico con parti dell'installazione elettrica collegata ad un conduttore di protezione.
- Utilizzare solamente dispositivi che hanno un isolamento supplementare tra i morsetti 1-10V/DALI e i morsetti di alimentazione.
- L'apparecchio è stato progettato e viene costruito nel rispetto delle normative in vigore; è necessario che l'installazione sia eseguita correttamente secondo le istruzioni.
- È altresì necessario conservare queste istruzioni e metterle a disposizione di tutti gli operatori che si occuperanno della normale manutenzione. L'inadempienza di quanto sopra comporta l'automatica decadenza della nostra responsabilità.



## INFORMATION TO THE CUSTOMERS

**Disposal of Old Electrical & Electronic Equipment (Applicable in the European Union and other European countries with separate collection system)**

This symbol on the product or in its packaging is based on WEEE Directive (Directive on Waste Electrical and Electronic Equipment), which is a regulation in EU member countries, and this symbol indicates that this product shall not be treated as household waste. To reduce the environmental impact and minimize the volume of landfills, please cooperate in reuse and recycle. For how to dispose of the product, please contact your dealer or the nearest AEC Illuminazione sales office.

## ATTENTION

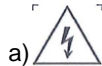

a)

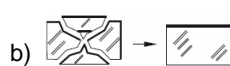

b)

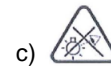

c)

- The light source contained in this luminaire shall only be replaced by the manufacturer or his service agent or a similar qualified person.
- Replace any cracked protective shield.
- During maintenance, do not stare at the operating light source.
- The mains cable of the luminaire has to be replaced only by the manufacturer, his service agent or qualified person.
- Class II luminaires must be installed in such a way that it is impossible for any exposed metal part to come in contact with electrical components.
- Use only devices with supplementary insulation between 1-10V/DALI terminals and mains terminals.
- The device has developed in compliance with the current standards; it is necessary that the installation is done properly, according with the instructions supplied.
- The present instruction paper has to be kept for any future maintenance operation on the luminaire. Non-compliance with the above will automatically release AEC Illuminazione Srl from any responsibility.



## INFORMATIONEN FÜR DIE KUNDEN!

**Entsorgen alter elektrischer & elektronischer Geräte (Gültig in der Europäischen Union und in anderen europäischen Ländern mit separaten Sammelsystemen)**

Dieses Symbol auf dem Produkt oder auf seiner Verpackung weist darauf hin, dass dieses Produkt nicht als Hausmüll behandelt werden soll. Zur Reduzierung der Umgebungseinflüsse durch WEEE (zu entsorgende elektrische und elektronische Geräte) und zum Minimieren der WEEE-Menge, die auf Deponien kommt, bitte wieder verwenden und recyceln. Weitere Informationen erhalten Sie bei Ihrem Händler vor Ort.

## HINWEISE

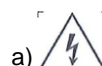

a)

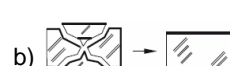

b)



c)

- Die Installation der Leuchte darf nur durch Fachpersonal erfolgen. Das Anschlusskabel darf nur durch Fachpersonal ausgetauscht werden.
- beschädigte Schutzschirme ersetzen
- Schauen Sie während der Wartung nicht auf die Lichtquelle
- Das Anschlusskabel darf nur durch Fachpersonal ausgetauscht werden.
- Leuchten der Schutzklasse II sind so zu installieren, dass kein ungeschütztes Metallteil mit elektrischen Bauteilen Berührung hat.
- Die Verdrahtung zwischen der 1-10V/DALI-Schnittstelle und der Anschlussklemme ist zusätzliche Isolierung.
- Die Installation ist sorgfältig und unter Beachtung der Montageanleitung durchzuführen.
- Bewahren Sie diese Montageanleitung für künftige Wartungsarbeiten an der Leuchte auf.
- Die Nichteinhaltung dieser Anleitung entbindet AEC Illuminazione GmbH von jeglicher Haftung.